

CRITICAL: MEASURE FROM TOP OF FINISHED FLOOR OR FLOOR COVERING TO TOP OF TRACK

MEASURE HEIGHT AT SEVERAL PLACES ACROSS THE OPENING

ALL DIMENSIONS IN PARENTHESES ARE MILLIMETERS.

NOTES:

- Headers prepared by others to carry concentrated live load of partition(s) across entire opening. See specifications for lbs. per sq. ft. Headers must be level. Sway bracing, if required, by others.
- At poured concrete floors, place screeds to hold variation to no more than 1/4" (6), plus or minus, in 10'-0" (3048), non-accumulative, 16" (406) either side of center line of track.
- All grounds for jambs to be plumb to 1/4" (6), plus or minus, from finished floor to top of track.
- All structural requirements and trim, except jamb mould or ceilingguard by others.

SURFACE TRACK WITH WOOD MOLDING BY WOODFOLD 4188

NOTE: # 14 X 2" (51) S.M. TRACK SCREWS

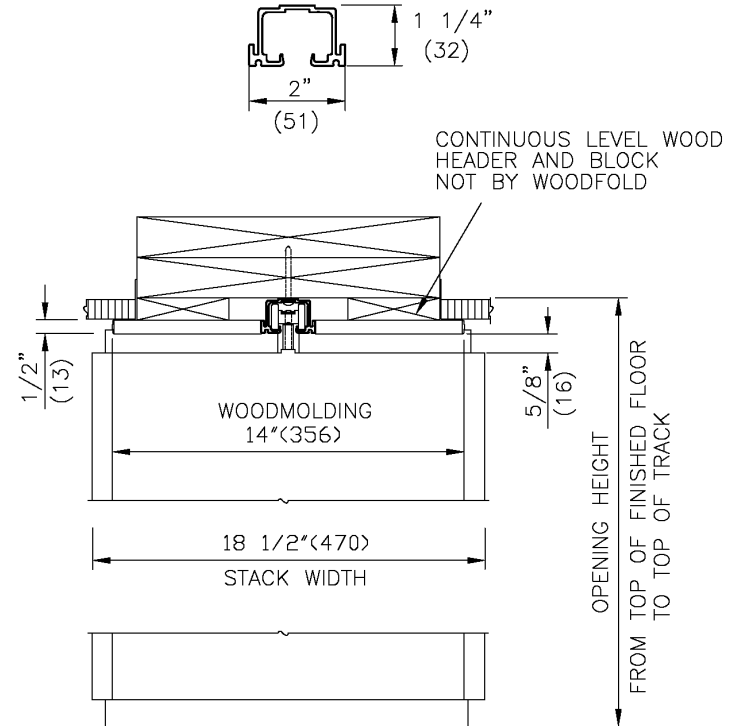
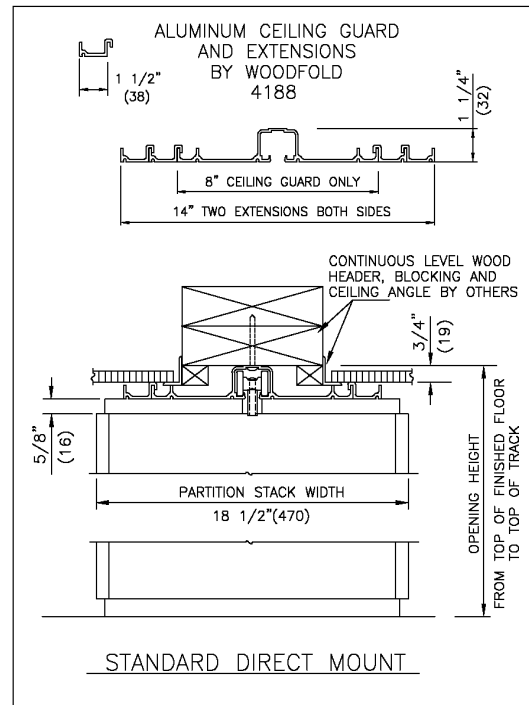
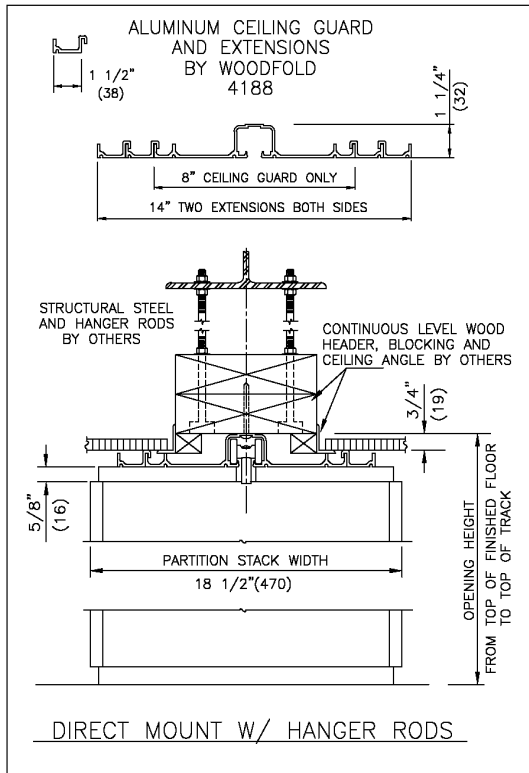

Woodfold Mfg, Inc.
Forest Grove, OR

PROJECT:	DATE
SHEET 1 OF 1	

Single Fixed (Left Hand)-Jamb Partition

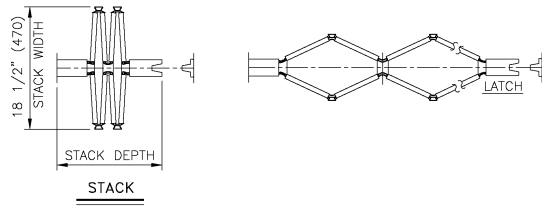

Single Fixed (Right Hand)-Jamb Partition

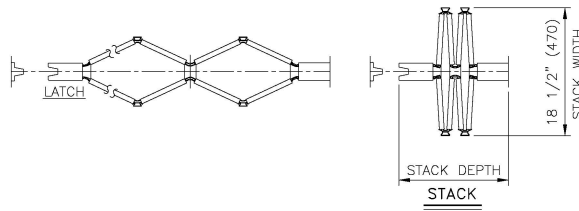

Double-End Post Partition

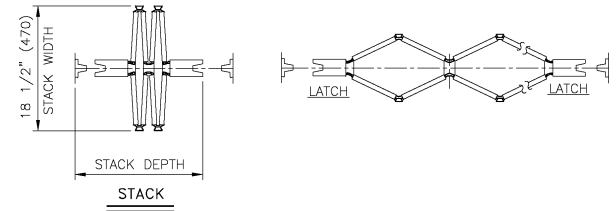

LEAD POST/JAMB MOLDING
WOODFOLD 4166/4188

Joining Pair Of Fixed-Jamb Partitions

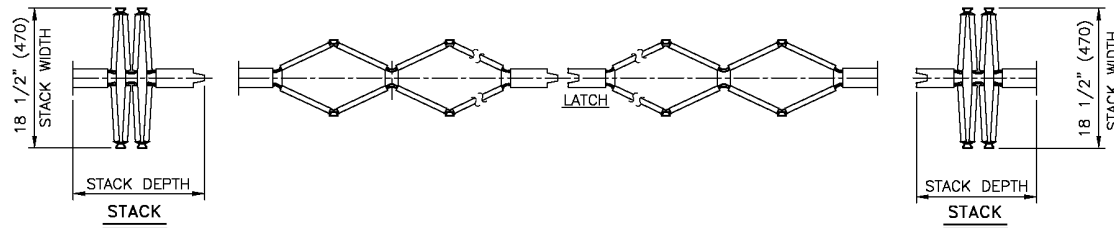
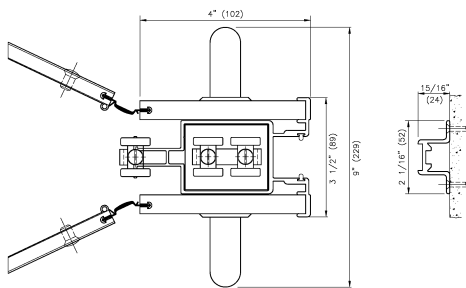

POST MOUNT
WOODFOLD 4166/4188

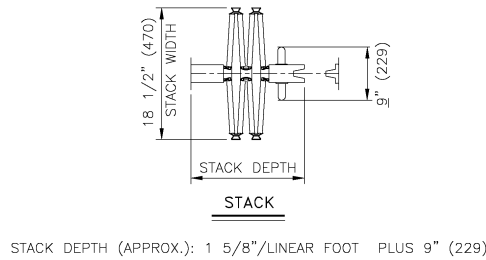
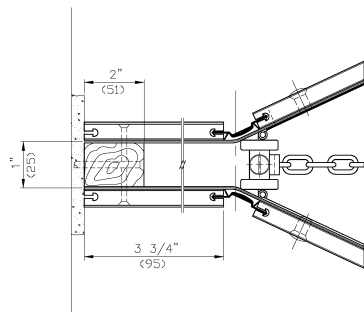

WOODFOLD 4188

Sliding Jamb Partition-Pocket Installation

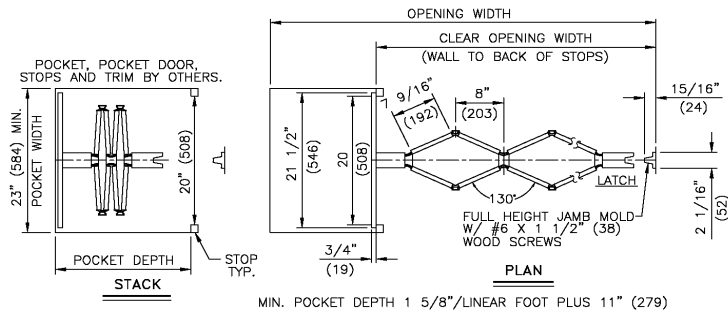

WOODFOLD 4188



Woodfold Mfg, Inc.
Forest Grove, OR

PROJECT:	DATE
	SHEET 2 OF 2