

Surface Track

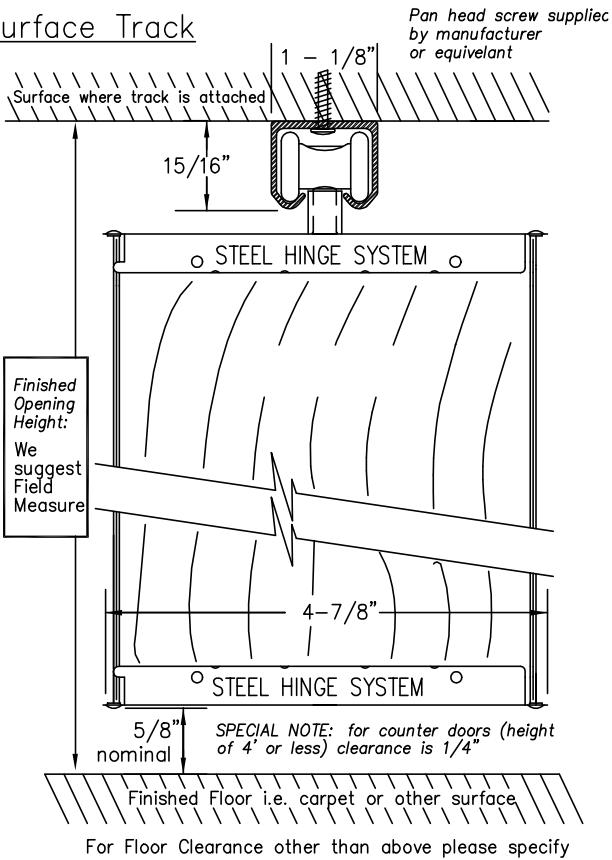

Recessed Track

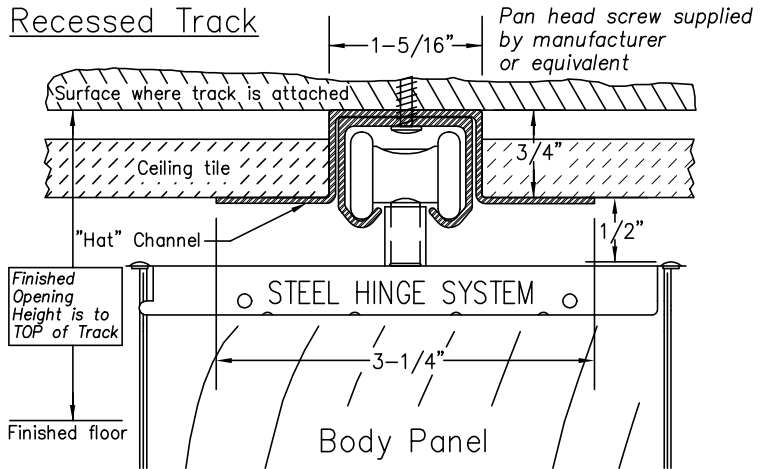

I-Beam Track

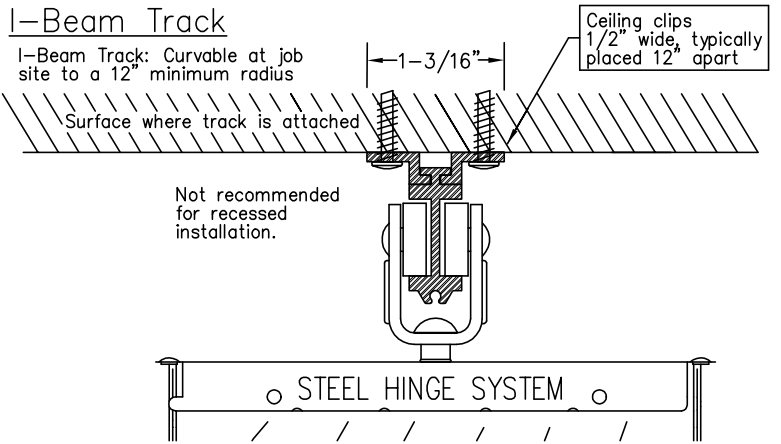

Door Types

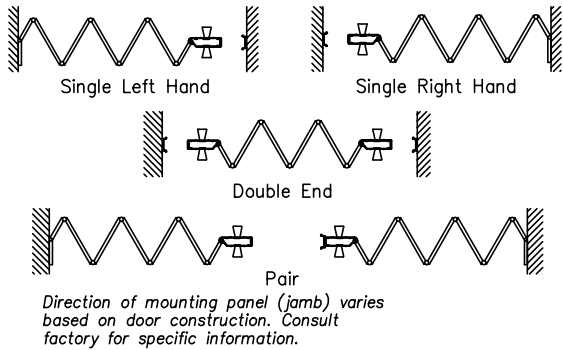

Lead Post, Jamb Mouldings & Handle

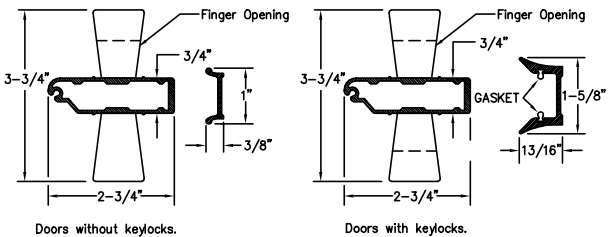

Sliding Jamb Option

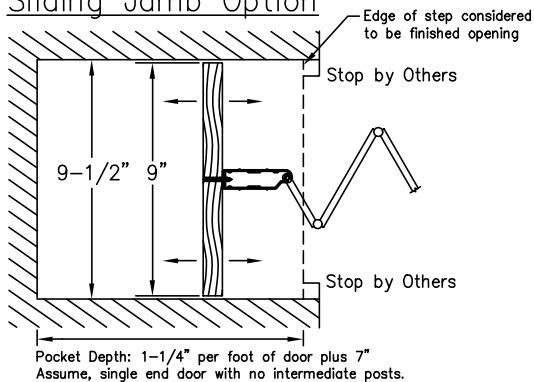

Mounting Panel

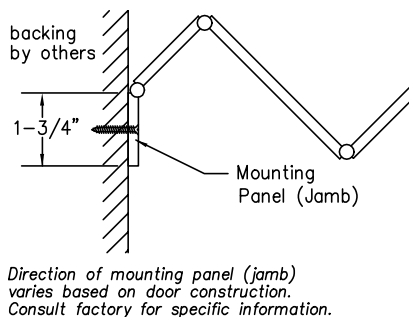

Multiple Meeting Option

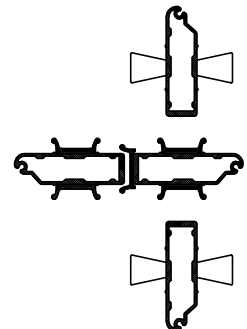

Stack Dimensions

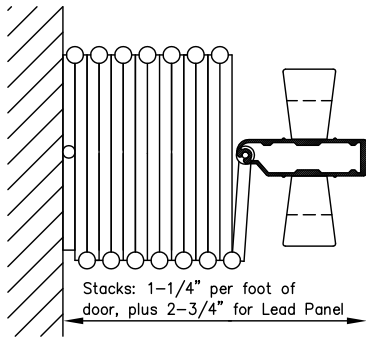

Stacks: 1-1/4" per foot of door, plus 2-3/4" for Lead Panel

Intermediate Rolling Post

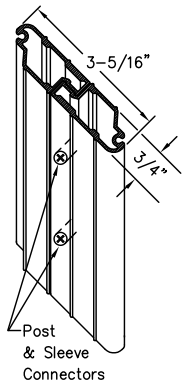

Privacy Latch



Keylock

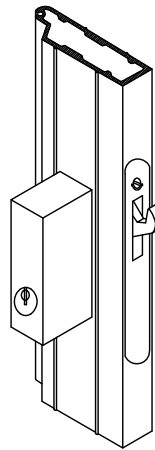

Single Cremone Bolt Keylock

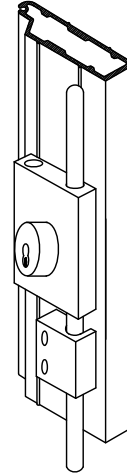

Double Cremone Bolt Keylock

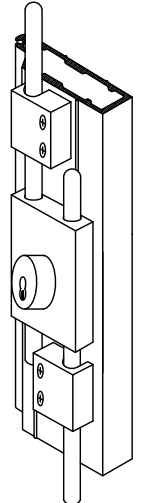

INFORMATION

| | | | | | | | | | | | |
|------------------------------------|--|---------------|-----------------------|-------|------------------------|-------|------------------------|--------|------------------------|--------|------------------------|
| Width | Custom made to any width | | | | | | | | | | |
| Height | Vinyl lam custom made to 12' -1" Hardwood veneer custom made to 10' -1" | | | | | | | | | | |
| Panels | Natural hardwood or vinyl-lam on MDF core | | | | | | | | | | |
| Panel Connector | Extruded Vinyl: White, Brown or Sand | | | | | | | | | | |
| Hinge System | Steel: Dark Bronze or Clear | | | | | | | | | | |
| Wheels | Ball bearing nylon wheels on steel axles | | | | | | | | | | |
| Track | Aluminum (straight or curvable): Dark bronze or Clear | | | | | | | | | | |
| Recessed Channel/ "Hat" Channel | Aluminum (straight only): White | | | | | | | | | | |
| Lead, Intermediate and Jamb | Aluminum: White, Brown or Sand Coordinated with panel connector | | | | | | | | | | |
| Latch | Deadlatch with thumb turn two sides | | | | | | | | | | |
| Header | Constructions Details by Others | | | | | | | | | | |
| Door Weight | <table border="0"> <tr> <td><u>Height</u></td> <td><u>Average Weight</u></td> </tr> <tr> <td>6'-8"</td> <td>10lbs. Per lineal foot</td> </tr> <tr> <td>8'-1"</td> <td>12lbs. Per lineal foot</td> </tr> <tr> <td>10'-1"</td> <td>15lbs. Per lineal foot</td> </tr> <tr> <td>12'-1"</td> <td>18lbs. Per lineal foot</td> </tr> </table> | <u>Height</u> | <u>Average Weight</u> | 6'-8" | 10lbs. Per lineal foot | 8'-1" | 12lbs. Per lineal foot | 10'-1" | 15lbs. Per lineal foot | 12'-1" | 18lbs. Per lineal foot |
| <u>Height</u> | <u>Average Weight</u> | | | | | | | | | | |
| 6'-8" | 10lbs. Per lineal foot | | | | | | | | | | |
| 8'-1" | 12lbs. Per lineal foot | | | | | | | | | | |
| 10'-1" | 15lbs. Per lineal foot | | | | | | | | | | |
| 12'-1" | 18lbs. Per lineal foot | | | | | | | | | | |

See Woodfold Accordion Door brochure for additional details

Catch/Lock Options

| | |
|---------------------|--|
| Magnet | Magnet with strike plate |
| Privacy Latch | Deadlatch with thumb turn one side |
| Springlatch | Springlatch with thumb turn two sides |
| Keylock 1 Side | Deadlatch with thumb turn one side, keylock one side |
| Keylock 2 Side | Deadlatch with keylock two sides |
| Single Cremone | Single cremone bolt with keylock |
| Double Cremone | Double cremone bolt with keylock |
| Footbolts | Locking or non locking |
| Other Keyed Options | Keyed alike, custom keyed, construction core Contact manufacture for more details |

Job Name: _____ Architects Acceptance

Job Location: _____

Supplier: _____

| Qty. | Single End/Double End | Left or Right Stack | Width X Height | Finish/Color | Comments |
|------|-----------------------|---------------------|----------------|--------------|----------|
| | | | | | |
| | | | | | |
| | | | | | |

THESE SPECIFICATIONS ARE SUBJECT TO CHANGE WITHOUT NOTICE