

Surface Track

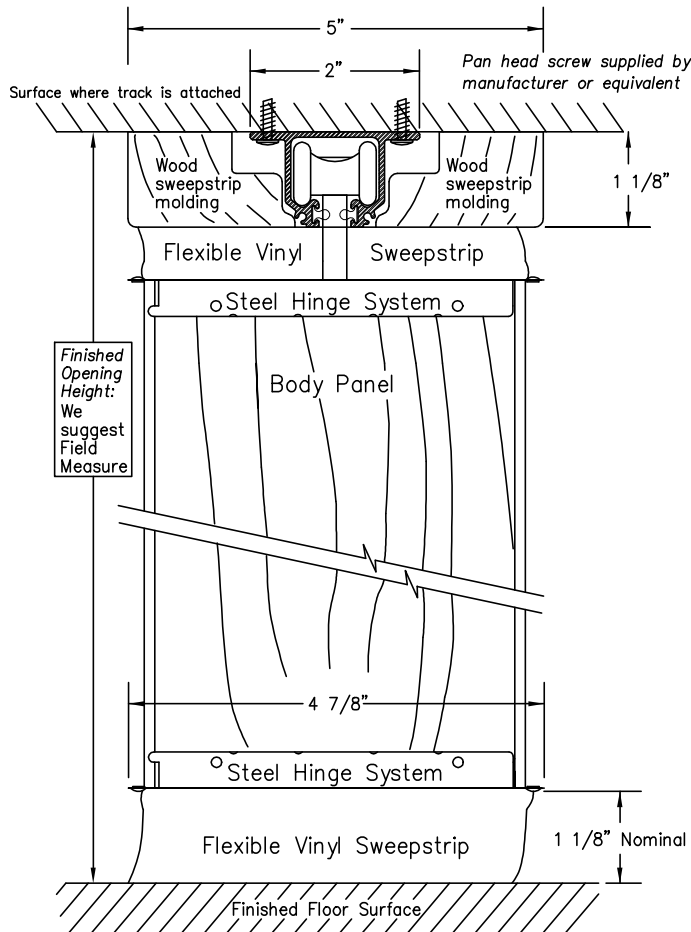

Sliding Jamb Option

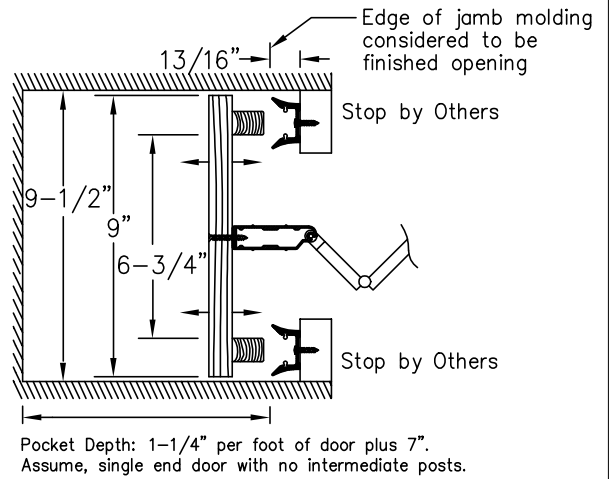

Lead Post, Jamb Moulding & Handle

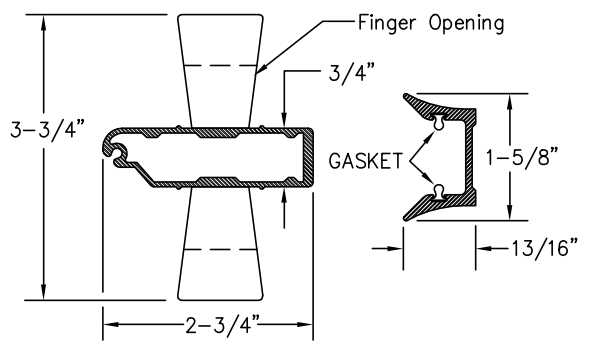

Door Types

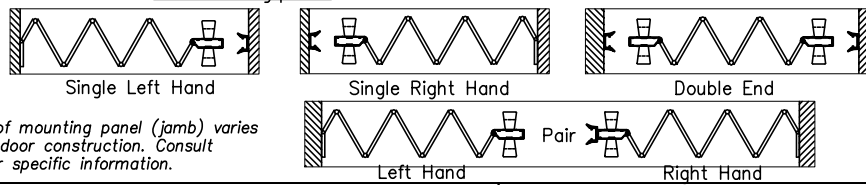

Direction of mounting panel (jamb) varies based on door construction. Consult factory for specific information.

Stack Dimensions

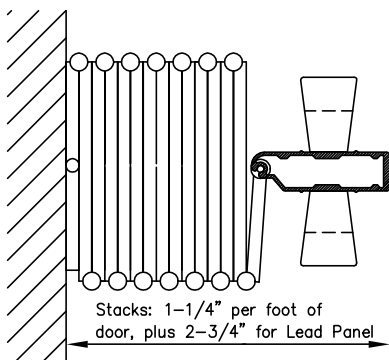

Mounting Panel

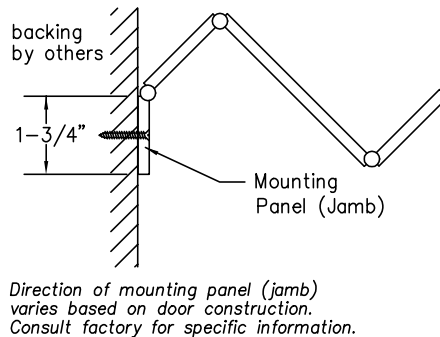

Multiple Meeting Option

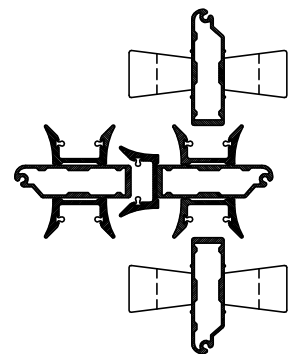

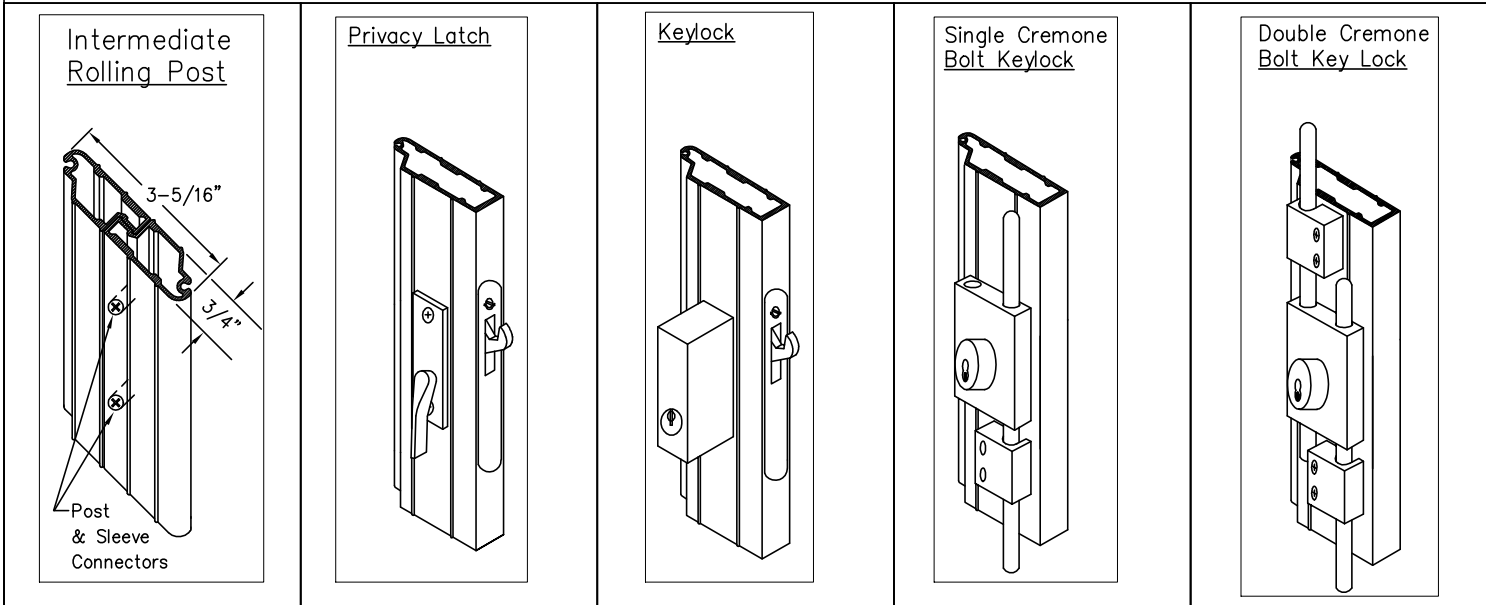

INFORMATION

Width	Custom made to any width										
Height	Vinyl lam custom made to 12' -1" Hardwood veneer custom made to 10' -1"										
Panels	Natural hardwood or vinyl-lam on MDF core										
Panel Connector	Extruded Vinyl: White, Brown or Sand										
Sweep Strip	Extruded Vinyl: White or Brown										
Hinge System	Steel: Dark Bronze or Clear										
Wheels	Ball bearing nylon wheels on steel axles										
Track	Aluminum (straight only): Dark bronze or Clear										
Lead, Intermediate and Jamb	Aluminum: White, Brown or Sand Coordinated with panel connector										
Latch	Deadlatch with thumb turn two sides										
Header	Construction Detail by Others										
Door Weight	<table border="0"> <tr> <td><u>Height</u></td> <td><u>Average Weight</u></td> </tr> <tr> <td>6'-8"</td> <td>10lbs. Per lineal foot</td> </tr> <tr> <td>8'-1"</td> <td>12lbs. Per lineal foot</td> </tr> <tr> <td>10'-1"</td> <td>15lbs. Per lineal foot</td> </tr> <tr> <td>12'-1"</td> <td>18lbs. Per lineal foot</td> </tr> </table>	<u>Height</u>	<u>Average Weight</u>	6'-8"	10lbs. Per lineal foot	8'-1"	12lbs. Per lineal foot	10'-1"	15lbs. Per lineal foot	12'-1"	18lbs. Per lineal foot
<u>Height</u>	<u>Average Weight</u>										
6'-8"	10lbs. Per lineal foot										
8'-1"	12lbs. Per lineal foot										
10'-1"	15lbs. Per lineal foot										
12'-1"	18lbs. Per lineal foot										

Catch/Lock Options

Magnet	Magnet with strike plate
Privacy Latch	Deadlatch with thumb turn one side
Springleatch	Springleatch with thumb turn two sides
Keylock 1 Side	Deadlatch with thumb turn one side, keylock one side
Keylock 2 Side	Deadlatch with keylock two sides
Single Cremone	Single cremone bolt with keylock
Double Cremone	Double cremone bolt with keylock
Footbolts	Locking or non locking
Other Keyed Options	Keyed alike, custom keyed, construction core Contact manufacture for more details

Job Name: _____
 Job Location: _____
 Supplier: _____

Architects Acceptance

See Woodfold Accordion Door brochure for additional details

Qty.	Single/Pair	Single End/Double End	Left or Right Stack	Width X Height	Finish/Color	Comments

THESE SPECIFICATIONS ARE SUBJECT TO CHANGE WITHOUT NOTICE