

WOODFOLD 140 & 220 INSTALLATION INSTRUCTIONS





Read and understand these instructions before proceeding. It saves frustration!



Examine the installation site before proceeding. Beginning installation before checking things out is discouraged.
***Measure Twice - Cut Once* so to speak**

1 Preparation

Preliminary Examination

Confirm the match of the packaged door to the intended opening. The sample label to the right shows the location of the critical information.



Inspect the packaging. If the package was damaged when it arrived, contact the shipping carrier first, then notify Woodfold.

Lay out the contents on a flat surface near the opening where the door is to be installed.

The package(s) contents should include

- ✓ Door
- ✓ Track Section(s)
- ✓ Hardware packet (Screws etc.)
- ✓ These instructions (Yes, yes, we know you had to find them if you're reading them, but we like to be complete.)
- ✓ A copy of the shipping label with all the information you need if you have to call Woodfold for any reason. Hold on to it for future reference.

Verify that the track length is correct.

Dry fit the track in the opening. The correct length will just fit into the opening. If needed, trim the track with a hacksaw. Try to keep the metal filings from mixing with grease inside the track.

If the track is too short by more than 1/2" contact Woodfold for a replacement track.

Even and Odd Door Panels

The factory puts in enough door panels to fill the opening. That seems obvious but it means some doors have an even number of panels and others an odd number. The consequence is that the mounting panel on your door may point in the other direction than those shown in illustrations.

DON'T PANIC! IT'S OK!

The factory just had to use a different number of panels than used in the illustration.

Opening Width	Right/Left Hand Single/Double End	Opening Height
2-5	x	6-6
Door Material	Rattan	
UPS	Bronze Hdwr Magnet Room Div	
	Sand Geon Fl. Cl. 0.5625	RH SE Reg Whls No
Door Series	220V Reg Bronze Trk	06-04-0447 None 2006-05-01
Block Height	5	
Block Width	5.5	1 @ 29
Crdbrd Width	15	
Cbrd Lgth	80.062	

Number of Track Pieces and Length

Order Number

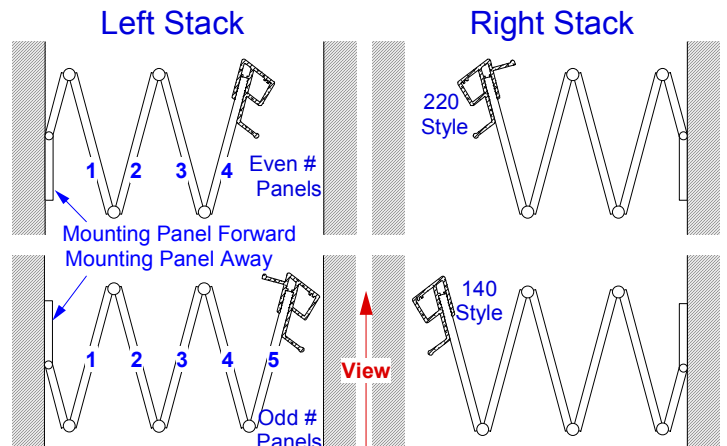

Power Screw Drivers: Check the length of your #2 Phillips Bit. It needs to extend at least 1 1/4" past the chuck. Any shorter and the chuck may tear up the track or the screw won't seat. It falls into the frustrating category when you have to ask Woodfold for a new track.



Caution! The factory greased the track for smooth operation! Hands and tools can spread the grease all over, so please be careful.



The next few steps are much easier if you have assistance.

2 Track Installation

Thread the track onto wheels; lineup the wheels properly in the track grooves. Be careful not to insert the wheels sideways. You won't like the result.

Confirm the proper orientation of the door. See the illustrations of Left or Right Stack or Double Ended doors lower on this page. Position the track to ensure: a) it can be securely attached to the header and b) the Mounting Panel can be securely attached to the wall or doorjamb.

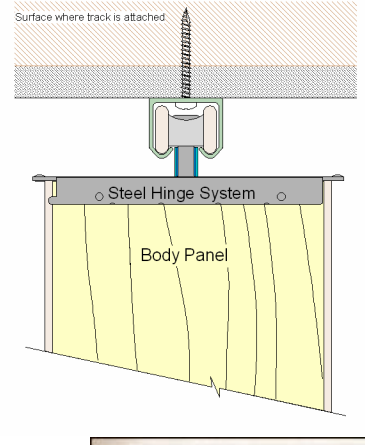

Stack the door to one end of the track (either side of the opening is OK) and attach the other end of the track to the header. Use 1 1/2" #8 pan head screws through the first 2 holes at the end of the track. Seat the head of the screw firmly against the track.

If the screws didn't go into a solid part of the header (soft stuff like sheet rock or acoustical tile doesn't count) at least 3/4", now would be a good time to go to the hardware store and get longer #8 Pan Head or Truss Head screws.



Caution! Firmly attach the track to the structural header! Sheetrock and many decorative materials do not provide adequate support.



Transfer the door to the attached end of the track. Finish attaching the track with 1 1/2" #8 Pan Head screws.



Check it out! Move the door back and forth along the track looking for smooth operation. Most frequent problems include screw heads sticking out, wheels sideways or debris in the track.



This next section is the most critical. Improperly installing the Mounting Panel results in the majority of trouble calls to Woodfold.

Repeat after me: **I will read this section. I will read this section.**

3. Mounting Panel

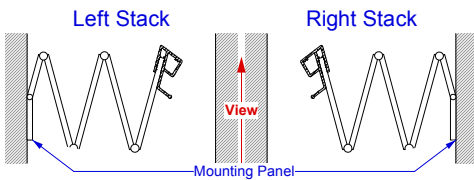

If your door has a mounting panel like one of those to the left, you need to read this Section.

If your door looks like the picture to the right, it is a double-ended door and you may skip ahead to Section 4.

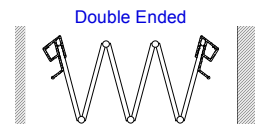

Push the door to the side that will be fastened permanently to the wall. Let the door form its own plumb (hang free) and carefully mark the wall with a pencil at the edge of the mounting panel near the top and bottom of the door.

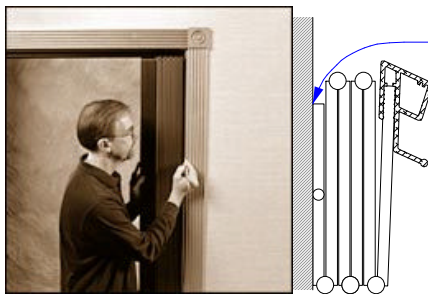

Mark wall near top and bottom of door at edge of Mounting Panel



It is important! Make the marks while the door is in its stacked position or the door will not close properly.

OK! Here comes the critical step. You just marked the wall at the top and bottom of the mounting panel edge with the door stacked. Now, extend the door to have access to the Mounting Panel. Hold the Mounting Panel edge at the pencil marks at both top and bottom!

Caution! Take care when attaching the Mounting Panel to the wall. As you unfold the door to insert the screws, the position of the Mounting Panel may move away from your marks. Trust your marks! Sometimes, the marks look "off" when the door is extended.

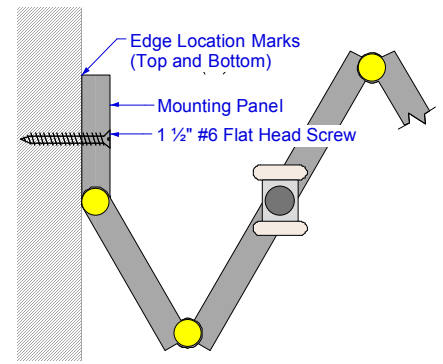

Insert 1 1/2" #6 flat head screws about 8" up from the floor and 8" down from the track.



Check it out! Can you see the pencil marks? If not, the door has shifted. If there is a gap between the edge and your marks, the door has shifted the other way. Stack the door against the Mounting Panel; it should form a neat, tight stack. DON'T Force it. If it binds, you missed your marks!

When the door stacks properly, re-extend it and install 2 more screws between the first 2, about equal distances apart.

4 Magnetic Latch

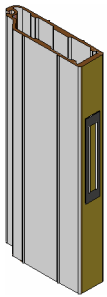

Center the Strike Plate on the magnet with the adhesive side out. Remove the protective tape from the adhesive backing and push the door firmly shut.

When you reopen the door, the strike plate should stay, temporarily stuck, in position.

Screw down the strike plate using 1 1/2" #6 Flat head screws.



Check it out! Open and close the door a few times then step back and admire your work.
Installation is complete!

Thank you for purchasing a Woodfold door.